

REFRIGERANT PIPE SUPPORT DETAIL
NO SCALE

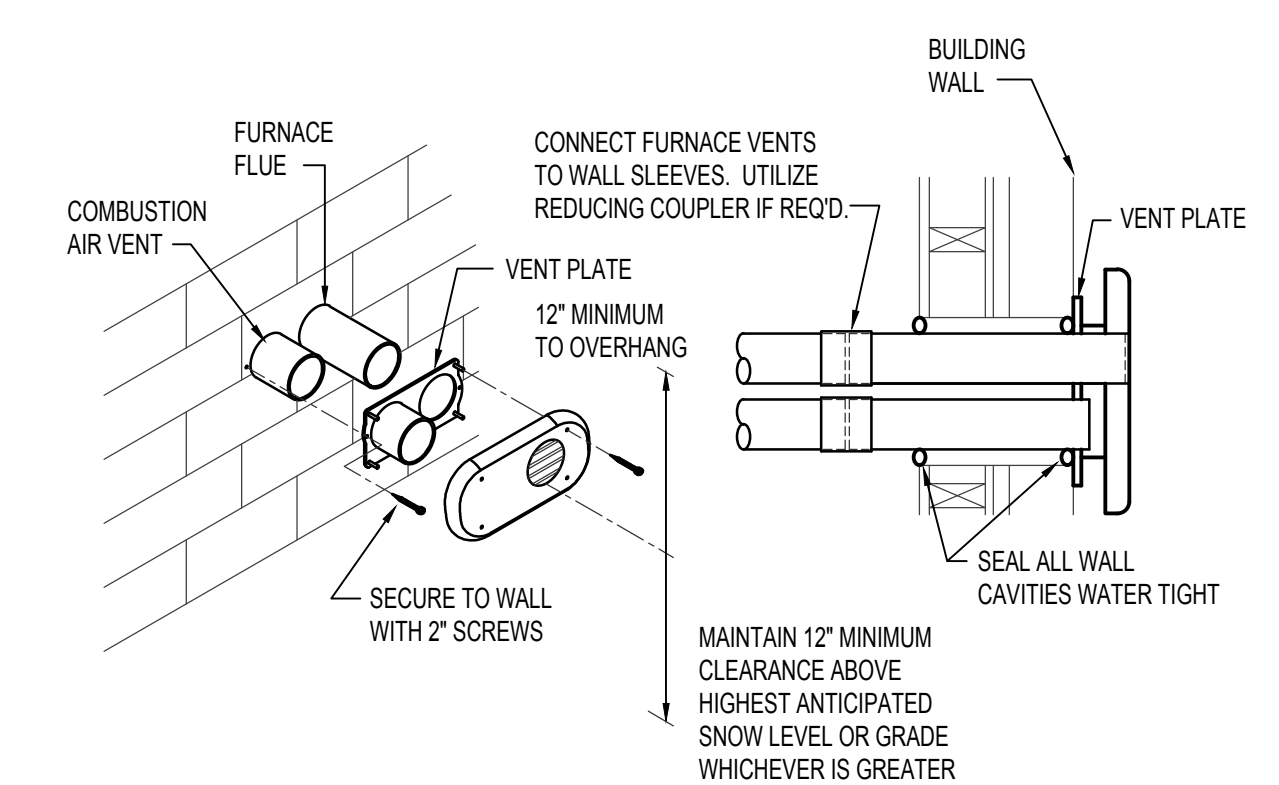

FURNACE VENT TERMINATION DETAIL
NO SCALE

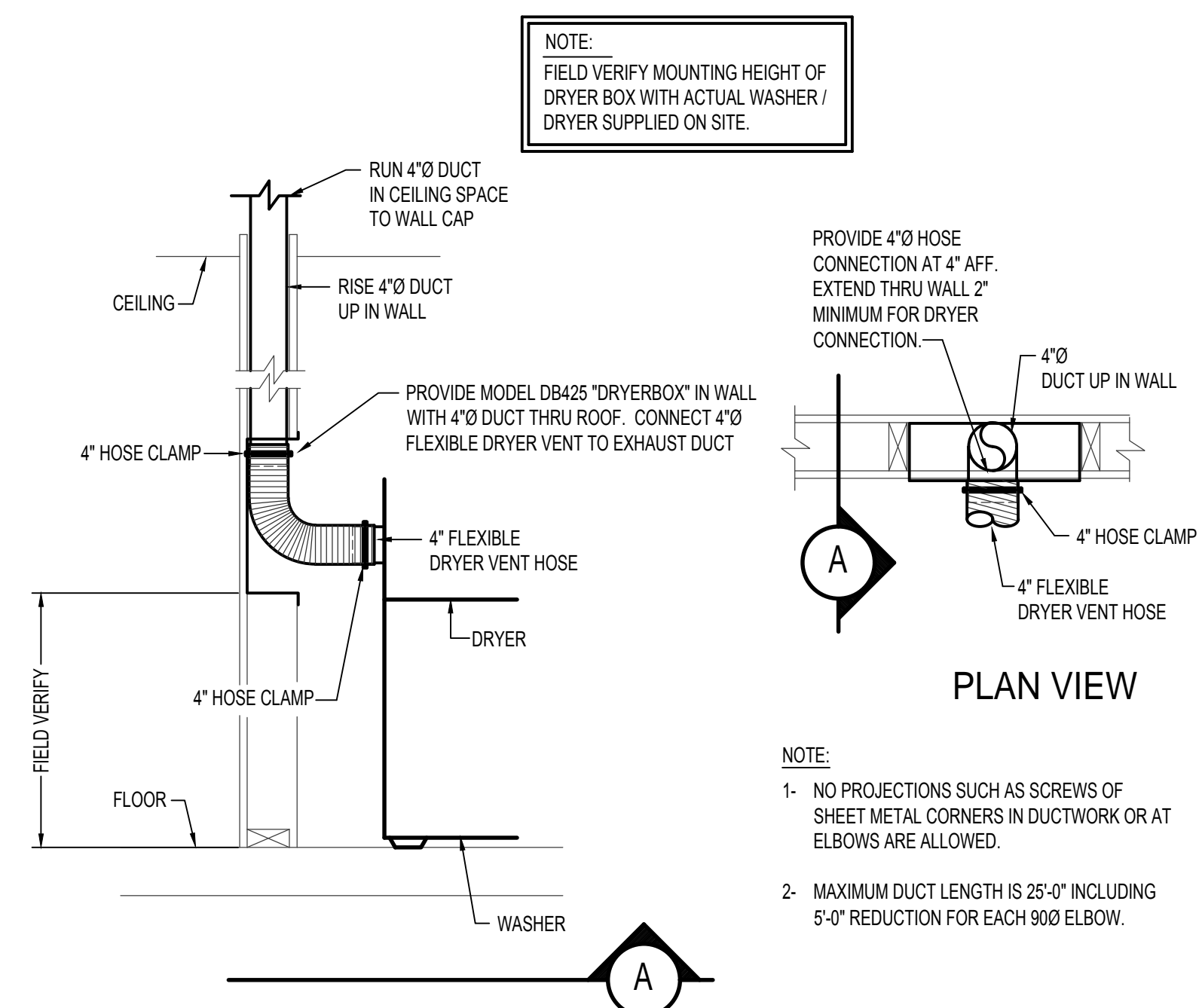

DRYER VENT DETAIL
NO SCALE

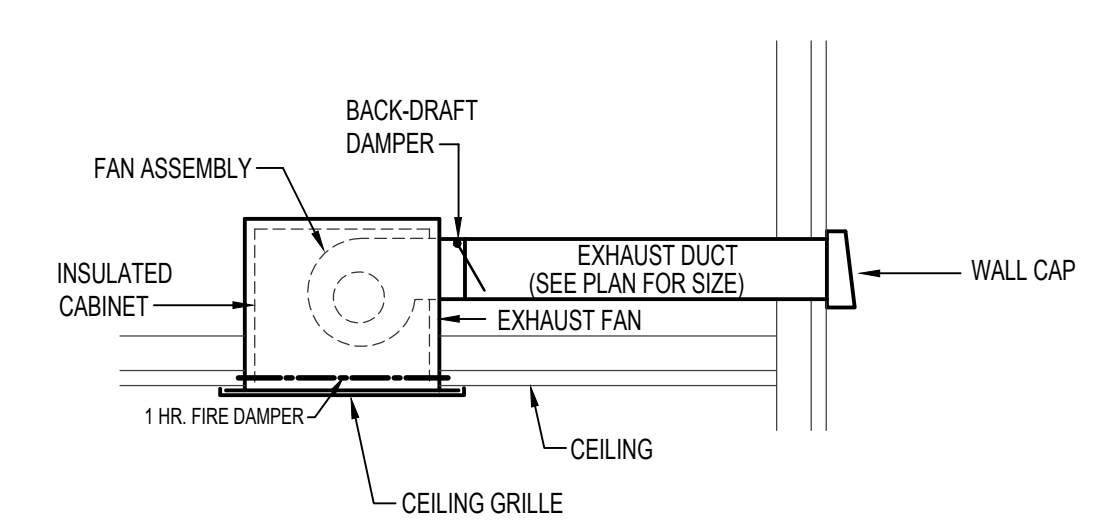

CEILING MOUNTED EXHAUST FAN DETAIL
NO SCALE

**BURLEY APARTMENTS
TWIN FALLS, IDAHO**

STAMP

ISSUE TYPE:	DATE:
△	-----
PROJECT NUMBER:	18-014
DRAWN BY:	Author
CHECKED BY:	Checker

**MECHANICAL
DETAILS**

M300

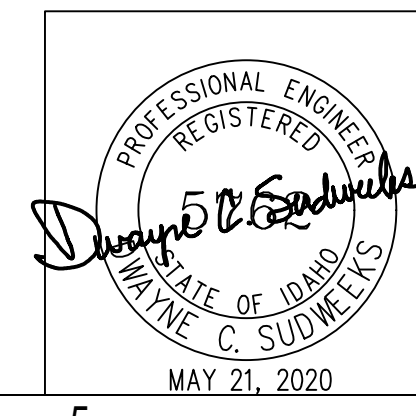

Engineered Systems Associates
1355 EAST CENTER
POCATELLO, IDAHO 83201
PHONE: (208) 233-0501
FAX: (208) 233-0529
EMAIL: esa@engsystems.com
ESA JOB NUMBER: 20018